

UN

90-2900T Hydraulic Series Technical Parameters



TUP . 202601 . 01B

TUP

TUP , It is one of the most advanced injection molding equipment manufacturers and complete system solution providers in China.

TUP provides the machines ranging from 90 to 6,600 tons, with the machine matrix of All-electric, Hybrid electric, Multi-components, Two / Three platens, which covers almost all main applications in automotive, packaging, medicals, engineering, 3C, home appliance, logistics etc.

The headquarter is located in hangzhou, zhejiang province, and the other remaining 15 branch offices, sales & service offices are located in China, SEA, America, Europe, Africa provide the nearby service to our customers.

With regarding to the capability, we have 200,000 square meters of manufacturing base, staffs over 500, annual machine output over 60,000 sets, R&D teams with around 100 skilled people, and annual R&D investment over 50 million of RMB, which coming to 100+ patents and more are on the que.

Technology, never stopping has always been our driving force to proceed. We are striving efforts to make constant progress, taking environmental protection, energy saving and high efficiency as our responsibilities, and are committed to providing customers with more comprehensive and valuable application solutions.

TECHNOLOGY NEVER STOPS!
TECHNOLOGY NEVER STOPS!
TECHNOLOGY NEVER STOPS!

TECHNOLOGY NEVER STOPS!

TECHNOLOGY NEVER STOPS!

TECHNOLOGY NEVER STOPS!

 **80,000+**
Annual Sales by Sets

 **100+**
Service Regions

 **6,000+**
Annual Capacity

 **200,000m²**
Factory Area





Hydraulic Series

In the production and R&D process of TUP UN series product line, we adhere to the concept of "innovation, for your every progress", take customer application as the starting point, adhere to reliable, stable and efficient production needs, and achieve the ultimate in detail optimization and adaptability.

Application Area



▽ 900-29,000kN



MORE RELIABLE

The whole industry chain production, self-made main parts
The repeatability of opening and closing the mold is < 1mm
The parallelism of the template < 0.2mm
Clamping force repeatability < 1%

MORE ENERGY EFFICIENT

Tie rod force deviation < ±3%
Injection repeatability: 3%
The static temperature control accuracy < ± 1°C
Melt-weight deviation < 0.5%

MORE EFFICIENT

Highly responsive servo power system
The maximum output can be reached in 50ms
>5% reduction in overall dry cycle time
Plasticizing capacity increased by >5%

MORE ADAPTABILITY

Modular design, more specifications to choose
from professional complete solutions

TECHNICAL ADVANTAGE

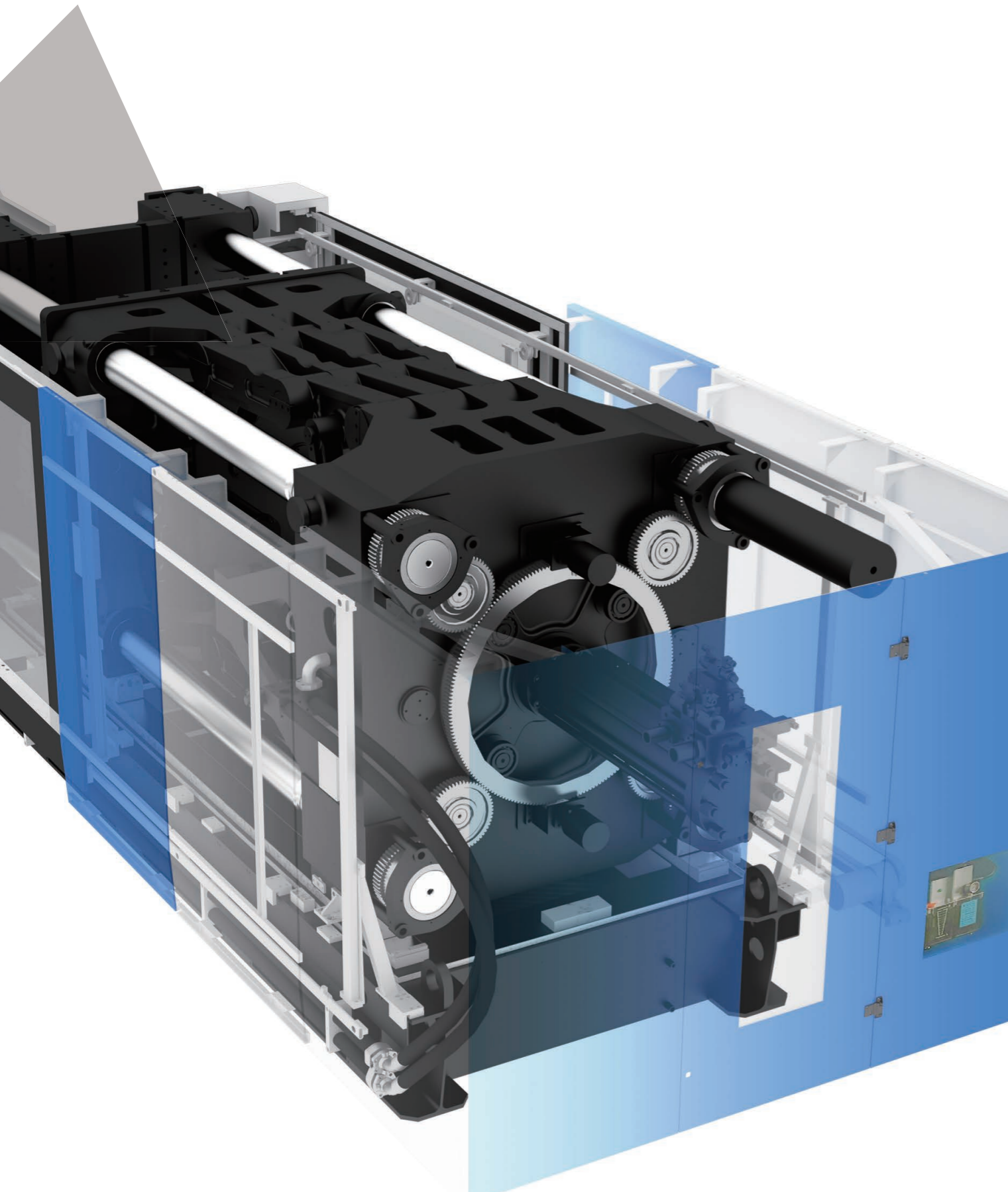

HIGH RIGIDITY INTEGRATED MOLD PLATE CASTING

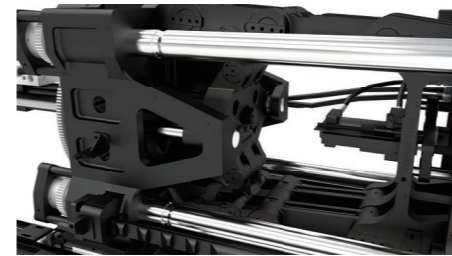
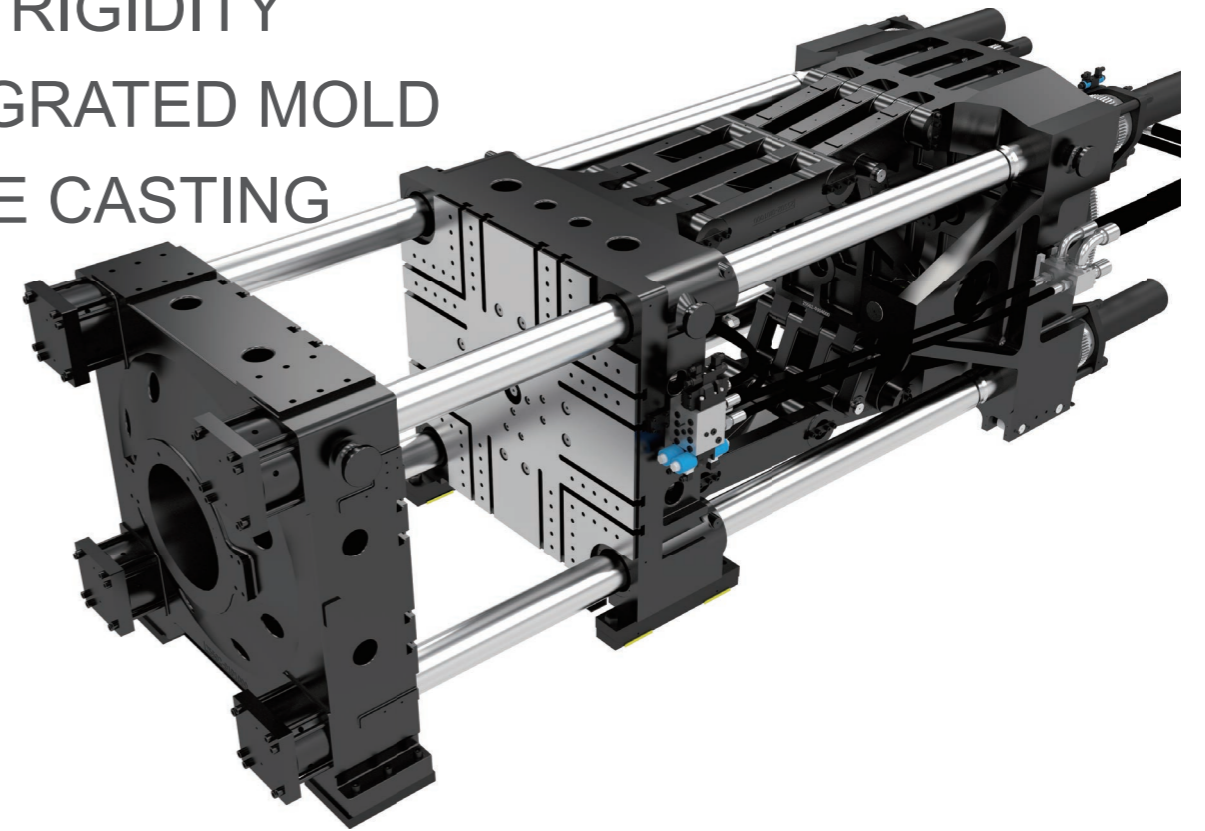

High-Rigidity Mold Plate Structure

△ Comprehensive optimization of mold plate design and parameter design using finite element software ensures stable operation and effectively guarantees product quality.

High-Rigidity Frame

△ A specially developed high-rigidity frame increases overall strength by 50%.

T-Slot Mold Plate Standard Across Full Series

△ T-slot design is standard on all models, facilitating mold loading/unloading and extending mold plate service life.

Extended Slide Feet Design

△ The moving plate adopts front-mounted heavy-duty support slide feet to prevent tilting, ensuring stable operation even with heavy molds.

Ejector Forced Return

△ Standard equipped with forced ejector return function, meeting special mold reset requirements and expanding mold compatibility.

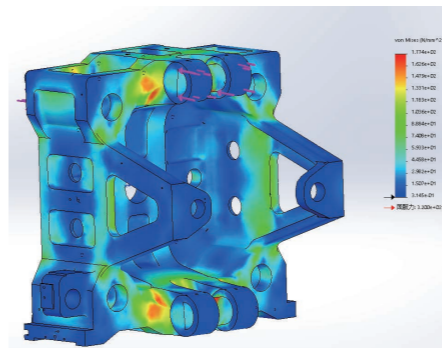

TECHNICAL ADVANTAGE

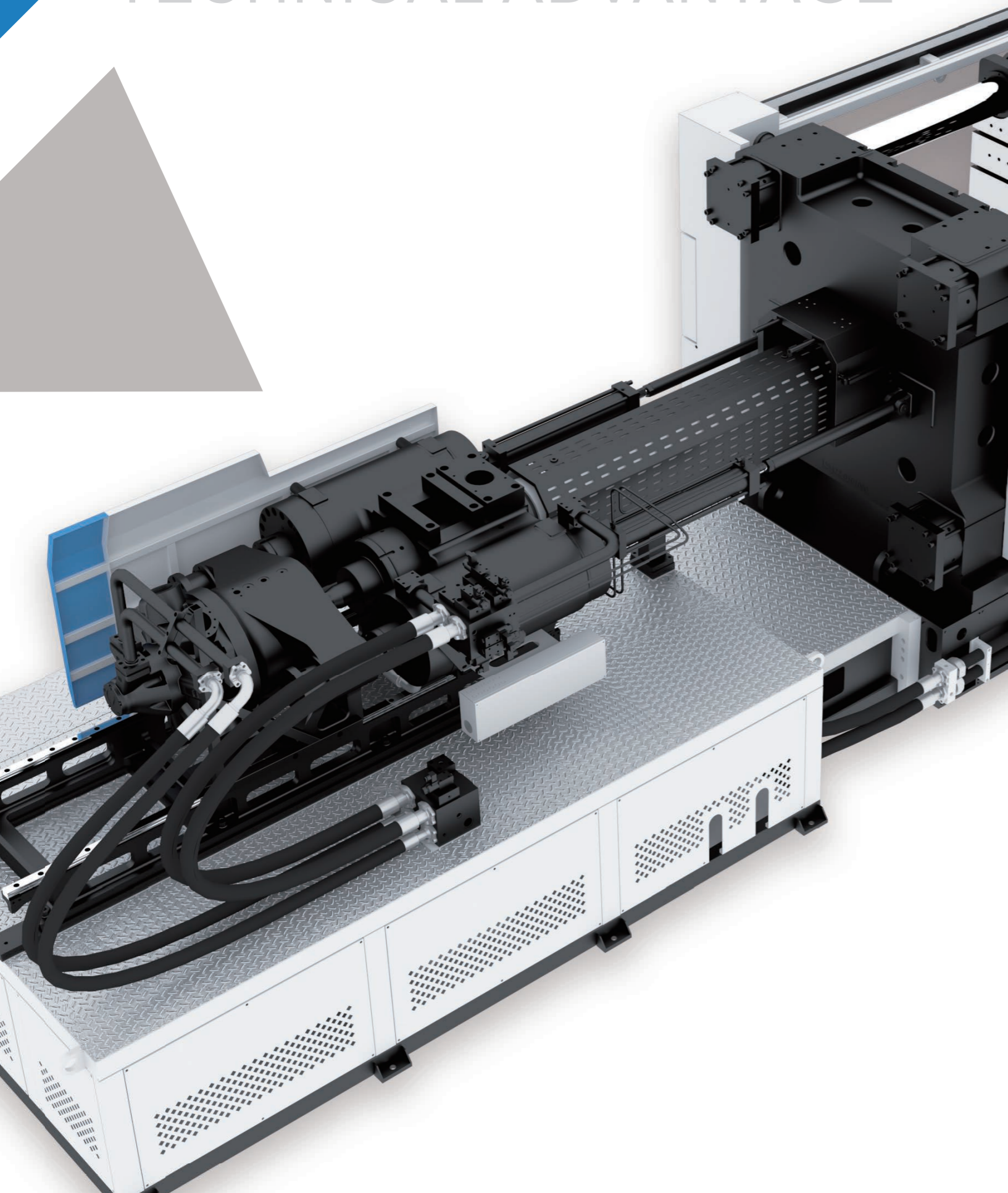

USER-FRIENDLY DESIGN LOW FRICTION COEFFICIENT

Dual-Cylinder Integrated Movement Structure

△ The injection oil cylinders are symmetrically arranged to ensure precise nozzle alignment. Stable injection and excellent sealing effectively prevent material leakage.

Double-Layer Linear Injection Structure

△ Supported by linear guides, it features low friction coefficient and minimal inertia, making it suitable for supporting heavy-duty hoppers.

Fully Closed-Loop Injection Control

△ Enables refined control of injection actions, high repeatability, strong process adaptability, and excellent low-speed stability—ideal for thick-walled product molding.

Standard CNC Back Pressure Control

△ Enables precise computer-controlled adjustment to enhance injection stability.

High-Efficiency Plasticizing Screw

△ The optimized screw and barrel design improves plasticization, increasing efficiency by 10%-30% while enhancing plasticizing quality and color mixing performance.

Additional User-Friendly Features

- △ Optional rotary injection unit for easier maintenance.
- △ Optional high-performance pre-plasticizing system to boost plasticizing efficiency and shorten cycle time.

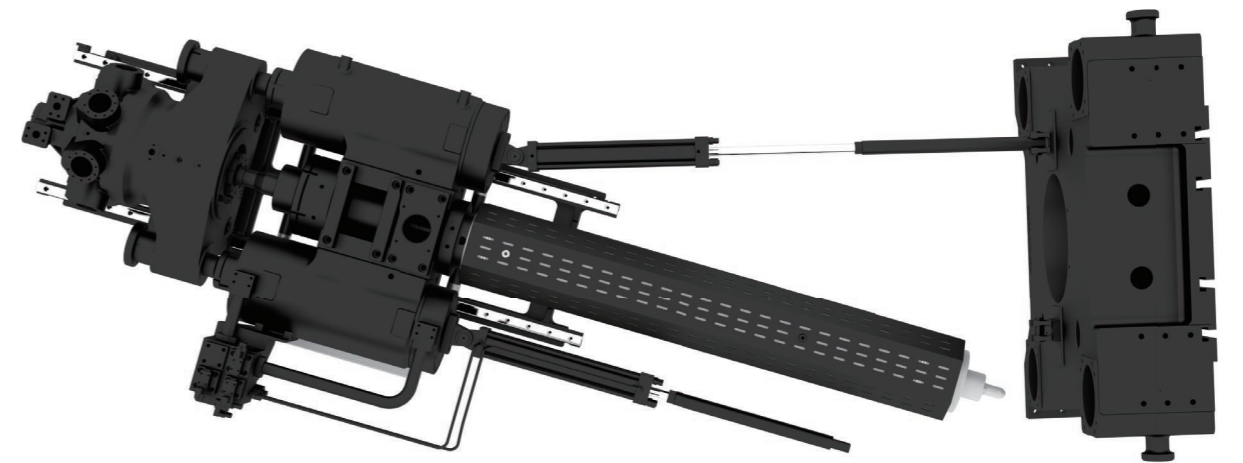

TECHNICAL ADVANTAGE

INTELLIGENT & INTEGRATED

Control System

- △ Large-screen control panel for a more user-friendly interactive experience.
- △ Intelligent energy consumption monitoring, system pressure, flow, position, and temperature control.
- △ Multi-functional interface with online multi-language switching.
- △ Optional smart MES networking management system.

High-Response Servo Motor Power Control System

- △ Equipped with a high-response servo motor and internal meshing gear pump power system, it achieves maximum output in just 0.05 seconds, effectively shortening the cycle and improving production efficiency.
- △ The servo motor power varies with the load, significantly saving electricity and water while maintaining low noise levels.

Intelligent Volumetric Lubrication Distribution System

- △ Ensures even oil distribution, high lubrication efficiency, and extends machine service life.

Built-in High-Efficiency Cooler

- △ Compact size, high cooling efficiency, simplified oil circuit design, ensuring stable oil temperature.

Quality Assurance

- △ Utilizes world-renowned brand electrical components.
- △ Standardized wiring layout with fully enclosed dustproof and waterproof electrical control box.

