

I4S 450-6600T

Two-platen Series
Technical Parameters

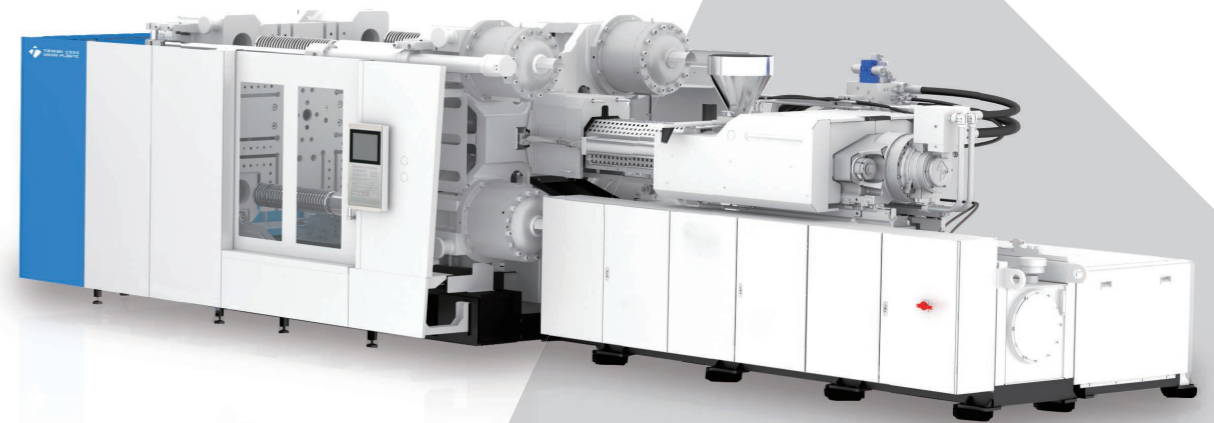

TUP . 202603 . 01B

TECHNOLOGY NEVER STOPS!
TECHNOLOGY NEVER STOPS!
TECHNOLOGY NEVER STOPS!

TECHNOLOGY NEVER STOPS!

TECHNOLOGY NEVER STOPS!

TECHNOLOGY NEVER STOPS!

TUP

TUP , It is one of the most advanced injection molding equipment manufacturers and complete system solution providers in China.

TUP provides the machines ranging from 90 to 6,600 tons, with the machine matrix of All-electric, Hybrid electric, Multi-components, Two / Three platens, which covers almost all main applications in automotive, packaging, medicals, engineering, 3C, home appliance, logistics etc.

The headquarter is located in hangzhou, zhejiang province, and the other remaining 15 branch offices, sales & service offices are located in China, SEA, America, Europe, Africa provide the nearby service to our customers.

With regarding to the capability, we have 200,000 square meters of manufacturing base, staffs over 500, annual machine output over 60,000 sets, R&D teams with around 100 skilled people, and annual R&D investment over 50 million of RMB, which coming to 100+ patents and more are on the que.

Technology, never stopping has always been our driving force to proceed. We are striving efforts to make constant progress, taking environmental protection, energy saving and high efficiency as our responsibilities, and are committed to providing customers with more comprehensive and valuable application solutions.

 **80,000+**
Annual Sales by Sets

 **100+**
Service Regions

 **6,000+**
Annual Capacity

 **200,000m²**
Factory Area



TUP-01

TUP-02



Two-platen Series

According to the development direction of large-scale injection molding machine, the hydraulic servo-driven Two-platen Series optimizes the design of each component, ensuring the performance indicators of most the parts aligning with the international level. The whole machine has a compact structure, large mold opening stroke, and is suitable for super-large cavity molds such as auto parts, home appliances, logistics, and pipe fittings.

Application Area



▽ 4,500-66,000kN

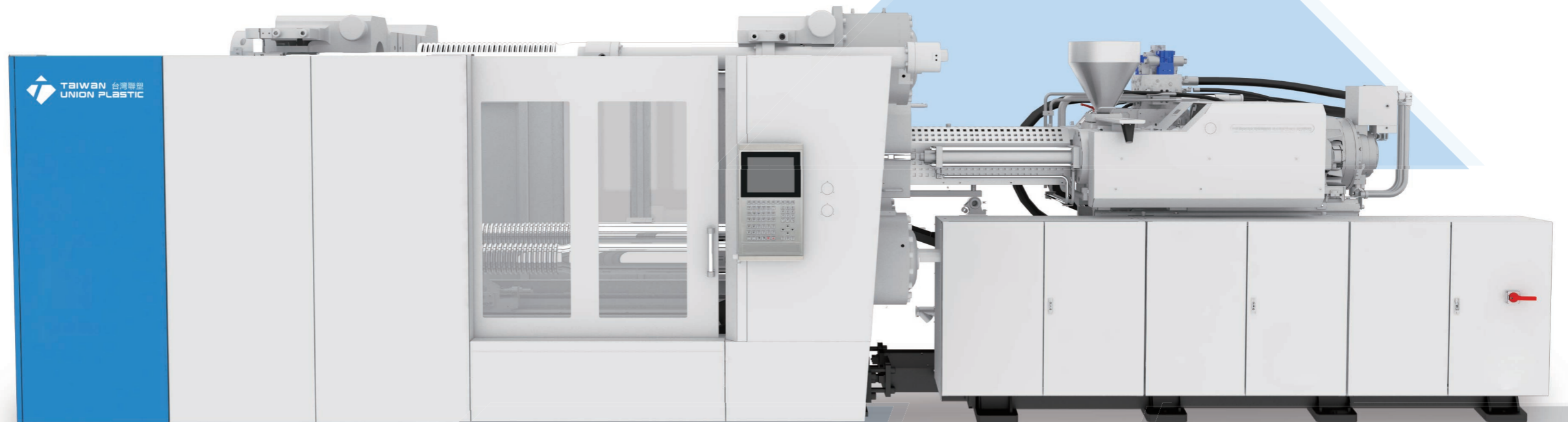

MORE STABLE

Large modulus, extendable mold shifting stroke
Mold support weight increased by 15%
Tie bar unbalanced load $\leq 4\%$
Barrel temperature control $\leq \pm 1^\circ\text{C}$



MORE PRECISE

The repeatability of the mold opening position $\leq \pm 0.1\text{mm}$
Injection repeatability $\leq 0.1\%$
Product quality repeatability $\leq 0.3\%$
The repeatability of the end position of the injection is $\pm 0.2\text{mm}$



MORE EFFICIENT

The speed of switching the mold is 1000mm/s
Efficiency increased by 50% compared to three-platen machine
High response servo system
The plasticizing parts have been fully upgraded



MORE ADAPTABILITY

Modular design, more specs to choose for professional complete solutions
More options like electric charging, tie bar pulling device, automatic mold change, MuCell etc.

TECHNICAL ADVANTAGE

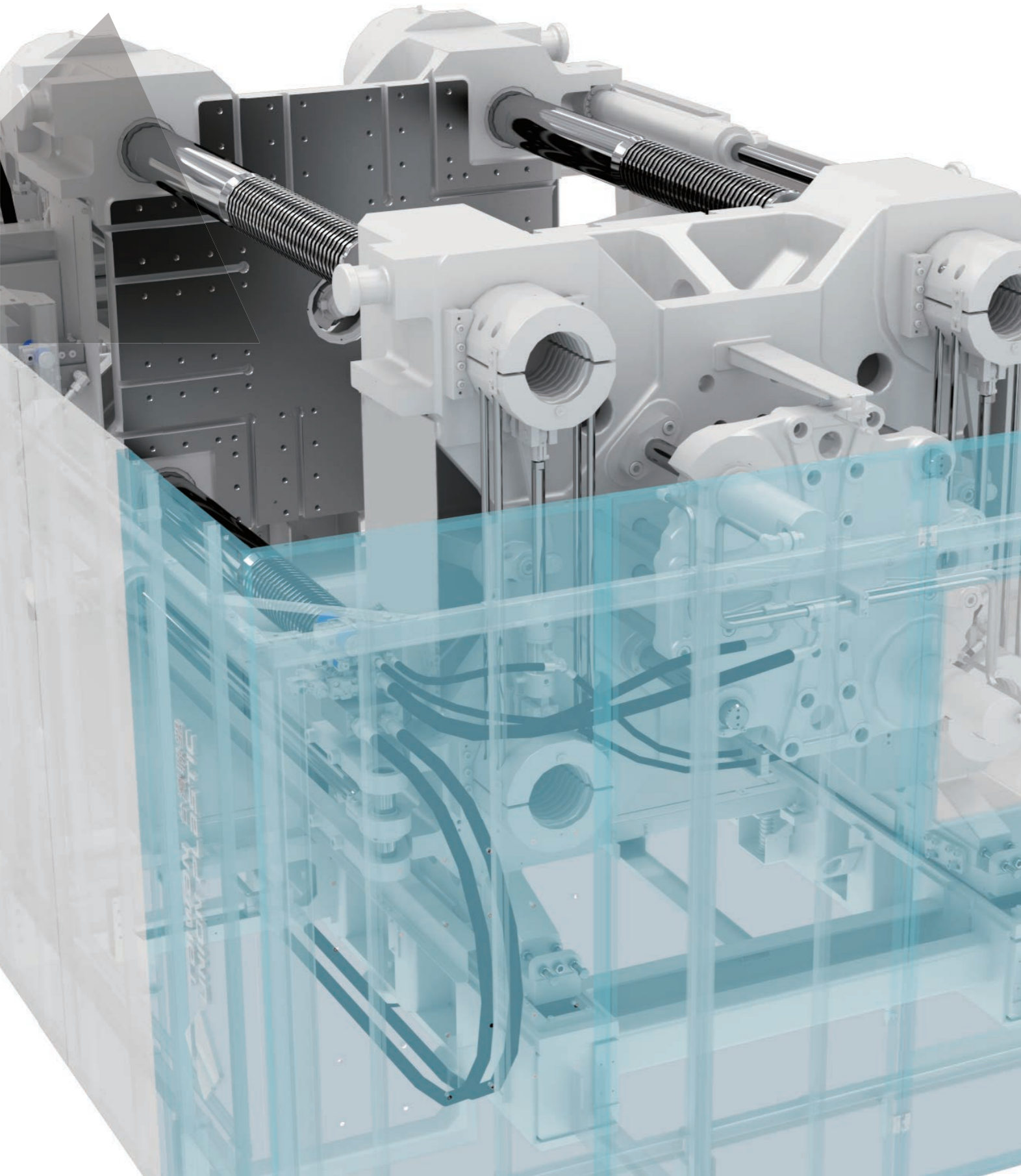

TWO-PLATEN STRUCTURE ULTRA-LARGE MOLD CAPACITY

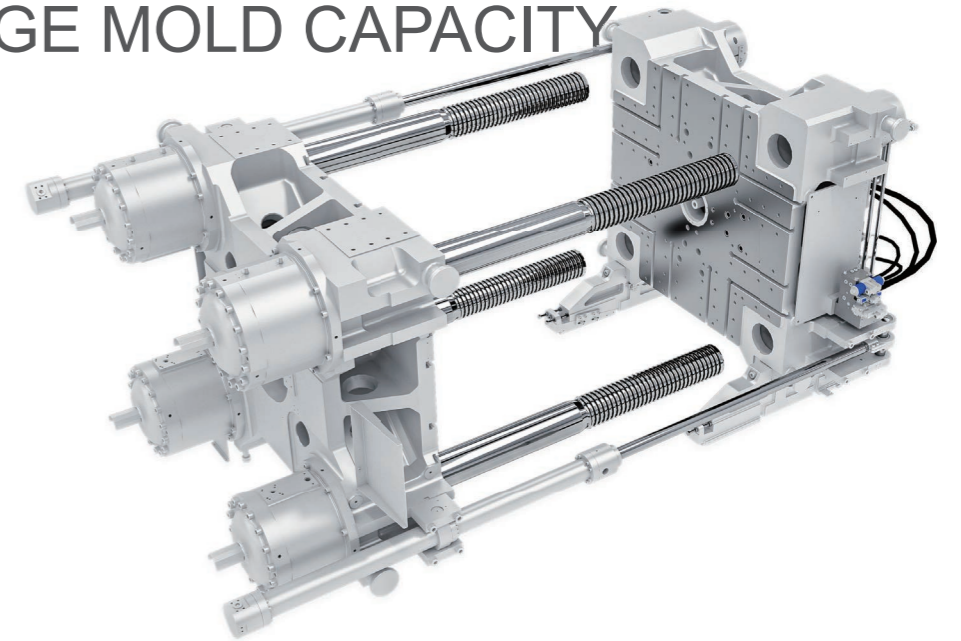

Two-Platen Structure

- △ Large mold opening stroke, wide adaptability, suitable for deep-cavity molds.
- △ Compact machine structure, small footprint, high factory space utilization.

High-Rigidity Mold Plate

- △ Minimal deformation verified by ANSYS analysis, ensuring smooth and fast mold opening/closing with high efficiency.
- △ High repeatability in mold opening positioning, meeting the precision requirements for automated part removal.

High-Pressure Oil Cylinder

- △ Unique high-pressure design with ultra-short stroke enables rapid pressure buildup.
- △ Symmetrical distribution ensures even mold force, with independent control and one-click mold adjustment.

Non-Contact Tie Bars

- △ Minimal deformation verified by ANSYS analysis, ensuring smooth and fast mold opening/closing with high efficiency.

Synchronized Brake Structure

- △ Short brake stroke, fast response, and precise braking.
- △ Brake cylinder with buffering function for low noise and shock-free operation.
- △ Fully sealed design, clean operation, and low maintenance cost.

Slide Feet

- △ High load-bearing capacity with excellent platen parallelism
- △ Precise linear guide alignment for enhanced mold protection
- △ Low frictional resistance enables fast mold closing speed

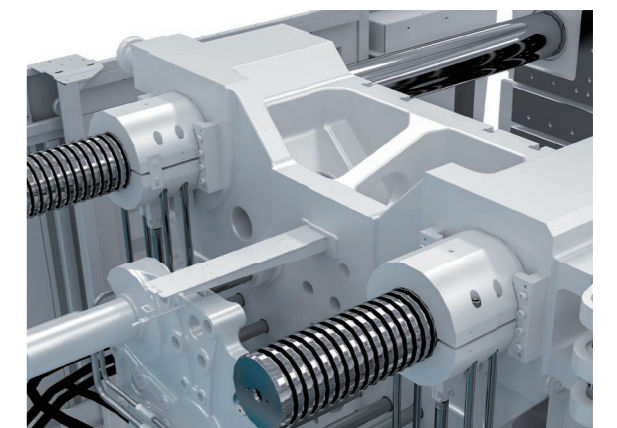
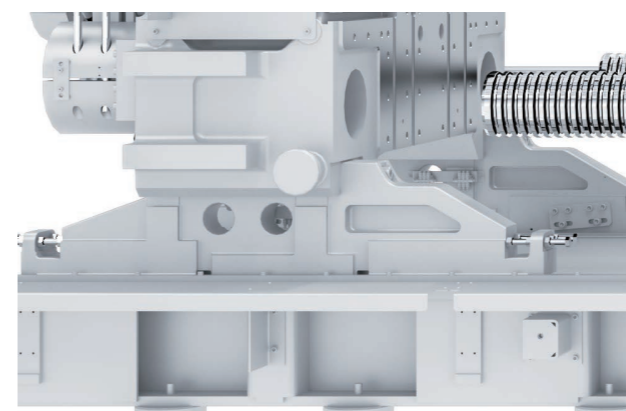

TECHNICAL ADVANTAGE

Electric Pre-plasticizing Unit (Optional)

Energy saving of 10%-20%

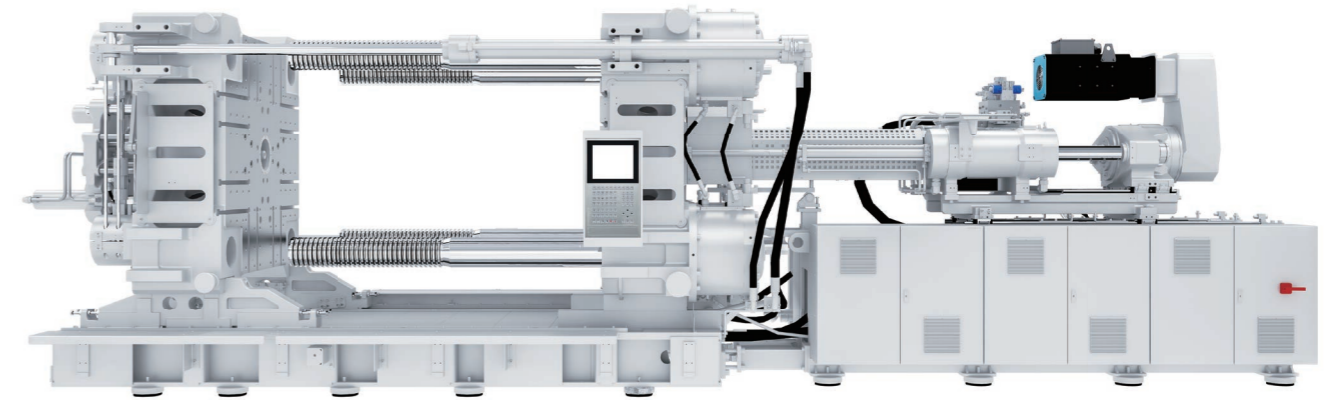
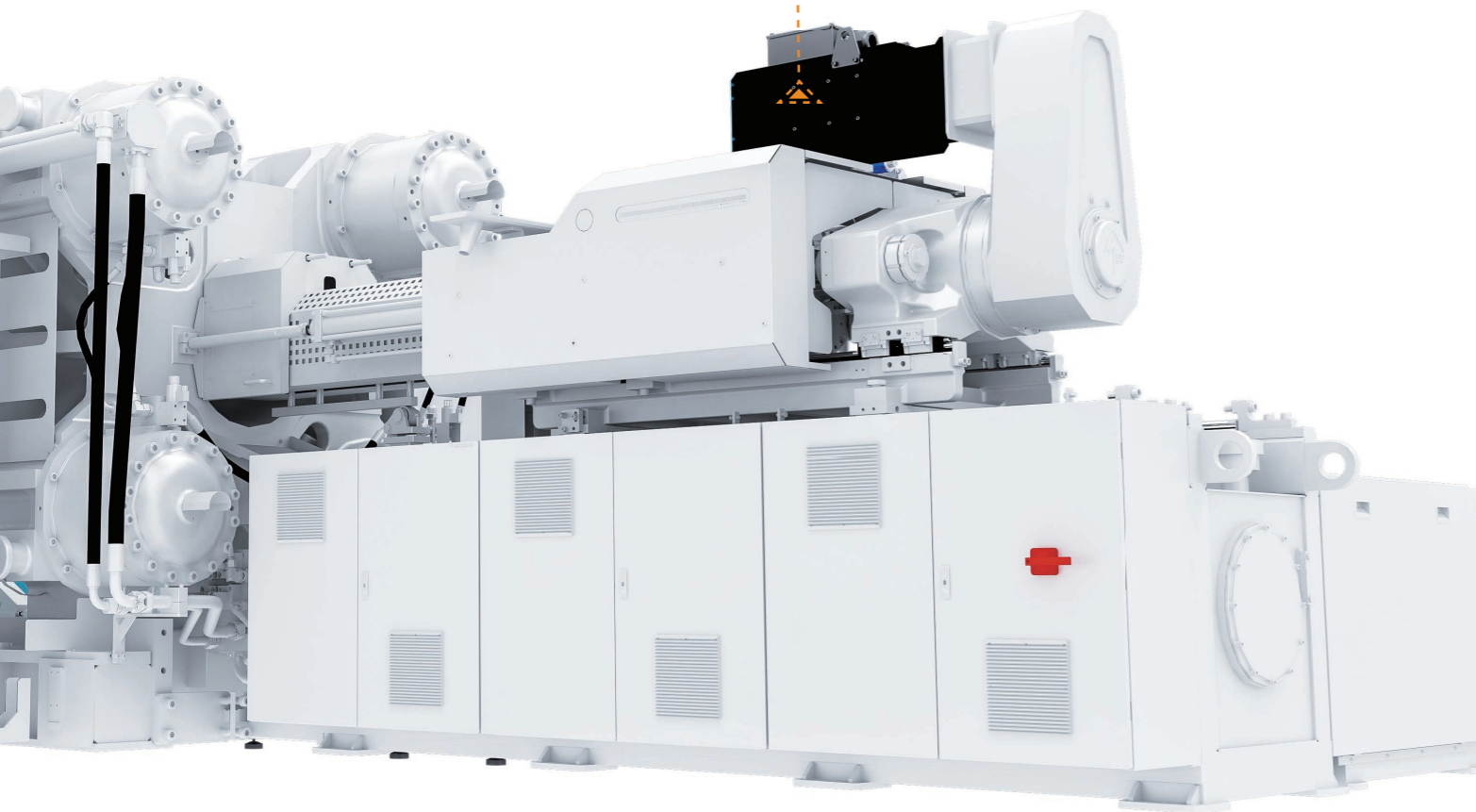

Integrated Injection Unit:

- △ Balanced double-cylinder injection device and balanced double-cylinder injection shifting oil cylinder for balanced force distribution.
- △ High-response drive injection device with fast response and long service life.
- △ Newly designed plasticizing system for enhanced plasticizing capacity.

Double-Layer Linear Guides:

- △ Linear guides are used for injection and injection shifting guidance, featuring low friction coefficient and smooth operation.
- △ Low injection inertia and high injection precision.

High-Response Servo System:

- △ Energy efficiency meets the national first-class standard, saving over 50% energy compared to traditional fixed pump models.

Independent Filtration and Cooling System:

- △ Utilizes an independent cooling system paired with a high-precision filter, delivering effective cooling and enhanced machine stability.

Advanced Hydraulic Design

- △ Optimized and shortened pipelines to minimize leakage points
- △ Rational power line layout for energy efficiency and environmental protection

More User-Friendly Functional Designs:

- △ Customizable for various process requirements with high adaptability
- △ Barrel support height fine-tuning structure for simple and convenient adjustment
- △ Detachable injection front plate cover significantly reduces screw replacement time
- △ Modular design structure to meet diverse product molding needs